

8. Resistance

Please remember to photocopy 4 pages onto one sheet by going A3→A4 and using back to back on the photocopier

Contents

Circuit Diagrams – Maths Questions.....	2
Questions involving thermistors	4
Resistivity	5
Wheatstone bridge and metre bridge	7
Solutions to ordinary Level <i>maths</i> questions.....	9
Solutions to <i>all</i> higher level questions	13

Circuit Diagrams – Maths Questions

For instructions on how to do these questions see the notes on the *Resistance* chapter

2007 Question 12 (c) [Ordinary Level]

The circuit diagram shows two resistors connected in series with a 6 V battery.

- State Ohm's law.
- Calculate the total resistance of the circuit.
- Calculate the current in the circuit.
- Calculate the potential difference across the $9\ \Omega$ resistor.
- Name an instrument used to measure potential difference.

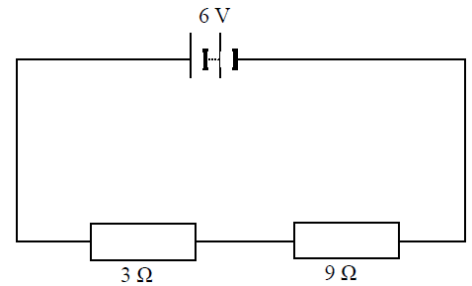

2018 Question 9 (c) [Ordinary Level]

The circuit diagram shows two resistors connected in series with a 3 V battery.

- State Ohm's law.
- Calculate the total resistance of the circuit.
- Calculate the current in the circuit.
- Calculate the potential difference across the $6\ \Omega$ resistor.
- Name an instrument used to measure potential difference.

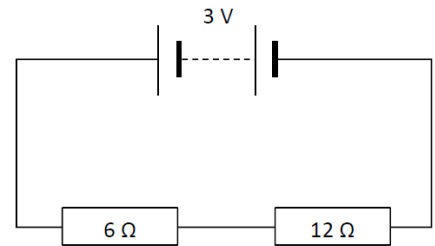

2002 Question 8 [Ordinary Level]

- Explain potential difference
- Explain electric current.
- Give one difference between conduction in metals and conduction in semiconductors.
- A circuit consists of a $3\ \Omega$ resistor and a $6\ \Omega$ resistor connected in parallel to a 1.5 V d.c. supply as shown.

Calculate the total resistance of the two resistors.

- Calculate the current flowing in the circuit.
- What is the current in the $3\ \Omega$ resistor?
- Semiconductors can be made p-type or n-type.
How is a semiconductor made p-type?
- Draw a diagram showing a p-n junction connected in forward bias to a d.c. supply.
- Give two uses of semiconductors.

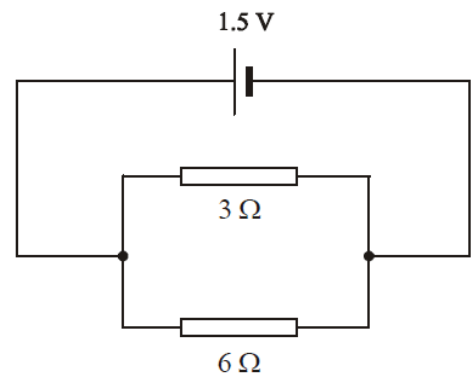

2008 Question 9 [Ordinary Level]

- An electric current flows in a conductor when there is a potential difference between its ends.
What is an electric current?
- Give two effects of an electric current.
- Name a source of potential difference.
- Describe an experiment to investigate if a substance is a conductor or an insulator.
- The two headlights of a truck are connected in parallel to a 24 V supply.
Draw a circuit diagram to show how the headlights are connected to the supply.
- What is the advantage of connecting them in parallel?
- Why should a fuse be included in such a circuit?
- The resistance of each headlight is $20\ \Omega$.
Calculate the total resistance in the circuit.
- Calculate the current flowing in the circuit.

2010 Question 9 (b) [Ordinary Level]

- (i) State Ohm's law
- (ii) The diagram shows a number of resistors connected to a 12 V battery and a bulb whose resistance is 4Ω . Calculate the combined resistance of the 15Ω and 30Ω resistors in parallel.
- (iii) Calculate the total resistance of the circuit
- (iv) Calculate the current flowing in the circuit

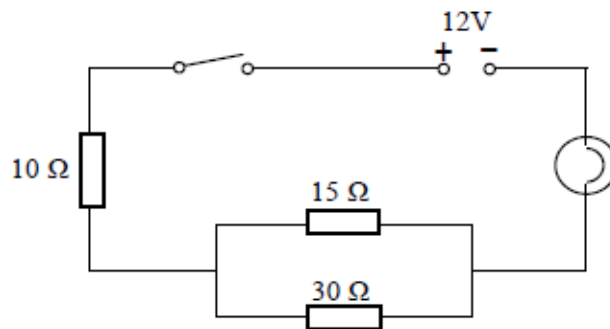

2016 Question 8 [Ordinary Level]

- (i) Define voltage and resistance.
- (ii) Name an instrument used to measure each of these quantities.
- (iii) Name a source of voltage.
- (iv) The diagram above shows a circuit with a 12 V d.c. power supply, an ammeter, and two 4Ω resistors connected in parallel. Calculate the total resistance of the circuit
- (v) Calculate the current flowing through the ammeter
- (vi) Calculate the current flowing through each resistor.
- (vii) One effect of an electric current is the heating effect. Name the two other effects of an electric current.
- (viii) Describe an experiment to demonstrate one of these two effects.

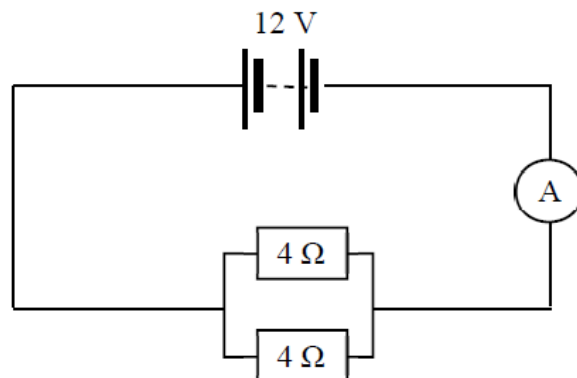

Questions involving thermistors

2014 Question 12 (d) [Ordinary Level]

The circuit diagram shows a resistor and a thermistor connected in series with a 6 V battery.
At a certain temperature the resistance of the thermistor is $450\ \Omega$.

- (i) State Ohm's law.
- (ii) What is the total resistance of the circuit?
- (iii) What is the current in the circuit?
- (iv) What is the potential difference across the $50\ \Omega$ resistor?
- (v) What would happen to the resistance of the circuit if the temperature were increased?

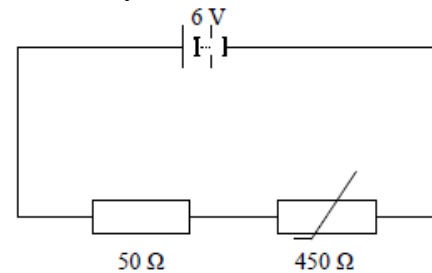

2005 Question 8 [Ordinary Level]

- (i) The circuit diagram shows a $100\ \Omega$ resistor and a thermistor connected in series with a 6 V battery.

At a certain temperature the resistance of the thermistor is $500\ \Omega$.
Calculate the total resistance of the circuit.

- (ii) Calculate the current flowing in the circuit.
- (iii) Calculate the potential difference across the $100\ \Omega$ resistor.
- (iv) As the thermistor is heated, what happens to the resistance of the circuit?
- (v) As the thermistor is heated, what happens to the potential difference across the $100\ \Omega$ resistor?
- (vi) Give a use for a thermistor.

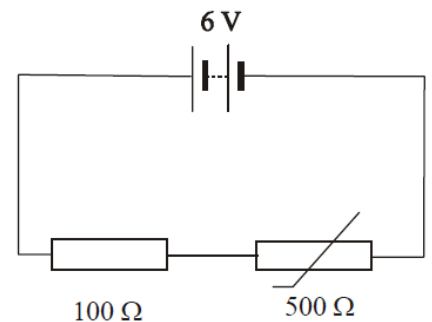

2005 Question 9 [Higher Level]

- (i) Define potential difference.
- (ii) Define resistance.
- (iii) Two resistors, of resistance R_1 and R_2 respectively, are connected in parallel. Derive an expression for the effective resistance of the two resistors in terms of R_1 and R_2 .
- (iv) In the circuit diagram, the resistance of the thermistor at room temperature is $500\ \Omega$.

At room temperature calculate the total resistance of the circuit.

- (v) At room temperature calculate the current flowing through the $750\ \Omega$ resistor.
- (vi) As the temperature of the room increases, explain why the resistance of the thermistor decreases.
- (vii) As the temperature of the room increases, explain why the potential at A increases.

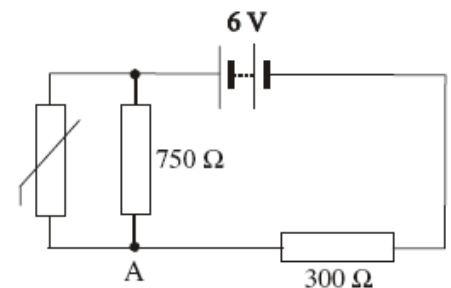

2005 Question 8 [Ordinary Level]

- (vii) State Ohm's Law.
- (viii) The graphs show how current (I) varies with potential difference (V) for (a) a metal, (b) a filament bulb.
Which conductor obeys Ohm's law?
- (ix) Explain your answer.

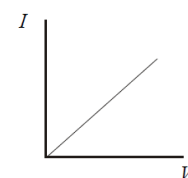

(a) a metal

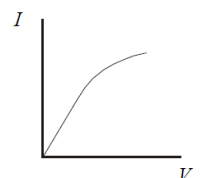

(b) a filament bulb

Resistivity

2002 Question 8 [Higher Level]

- (i) Define power.
- (ii) Define resistivity.
- (iii) Describe an experiment that demonstrates the heating effect of an electric current.
- (iv) The ESB supplies electrical energy at a rate of 2 MW to an industrial park from a local power station, whose output voltage is 10 kV.
The total length of the cables connecting the industrial park to the power station is 15 km. The cables have a diameter of 10 mm and are made from a material of resistivity $5.0 \times 10^{-8} \Omega \text{ m}$.
Calculate the total resistance of the cables.
- (v) Calculate the current flowing in the cables.
- (vi) Calculate the rate at which energy is “lost” in the cables.
- (vii) Suggest a method of reducing the energy “lost” in the cables.

2013 Question 8 (b) [Higher Level]

- (i) Electricity generating companies transmit electricity over large distances at high voltage.
Explain why high voltage is used.
- (ii) A 3 km length of aluminium wire is used to carry a current of 250 A.
The wire has a circular cross-section of diameter 18 mm.
Calculate the resistance of the aluminium wire.
- (iii) Calculate how much electrical energy is converted to heat energy in the wire in ten minutes.
(resistivity of aluminium = $2.8 \times 10^{-8} \Omega \text{ m}$)

2008 Question 7 [Higher Level]

- (i) Define resistivity and give its unit of measurement.
- (ii) An electric toaster heats bread by convection and radiation.
What is the difference between convection and radiation as a means of heat transfer?
- (iii) A toaster has a power rating of 1050 W when it is connected to the mains supply.
Its heating coil is made of nichrome and it has a resistance of 12 Ω .
The coil is 40 m long and it has a circular cross-section of diameter 2.2 mm.
Calculate the resistivity of nichrome.
- (iv) Calculate the heat generated by the toaster in 2 minutes if it has an efficiency of 96%.
- (v) The toaster has exposed metal parts. How is the risk of electrocution minimised?
- (vi) When the toaster is on, the coil emits red light.
Explain, in terms of movement of electrons, why light is emitted when a metal is heated.

2011 Question 12 (c) [Higher Level]

- (i) List the factors that affect the heat produced in a current-carrying conductor.
An electric cable consists of a single strand of insulated copper wire.
The wire is of uniform cross-sectional area and is designed to carry a current of 20 A.
To preserve the insulation, the maximum rate at which heat may be produced in the wire is 2.7 W per metre length.
- (ii) Calculate the maximum resistance per metre of the wire
- (iii) Calculate the minimum diameter of the wire.
(resistivity of copper = $1.7 \times 10^{-8} \Omega \text{ m}$)

2010 Question 8 [Higher Level]

A hair dryer with a plastic casing uses a coiled wire as a heat source. When an electric current flows through the coiled wire, the air around it heats up and a motorised fan blows the hot air out.

- (i) What is an electric current?
- (ii) Heating is one effect of an electric current.
Give two other effects of an electric current.
- (iii) The diagram shows a basic electrical circuit for a hair dryer.
Describe what happens when switch A is closed and the rheostat is adjusted
- (iv) Describe what happens when switch A and switch B are closed.
- (v) Calculate the current that flows through the coil when the dryer is turned on.
The maximum power generated in the heating coil is 2 kW.
- (v) What is the initial resistance of the coil?
- (vii) A length of nichrome wire of diameter 0.17 mm is used for the coil.
Calculate the length of the coil of wire. (resistivity of nichrome = $1.1 \times 10^{-6} \Omega \text{ m}$)
- (viii) Explain why the current through the coil would decrease if the fan developed a fault and stopped working.

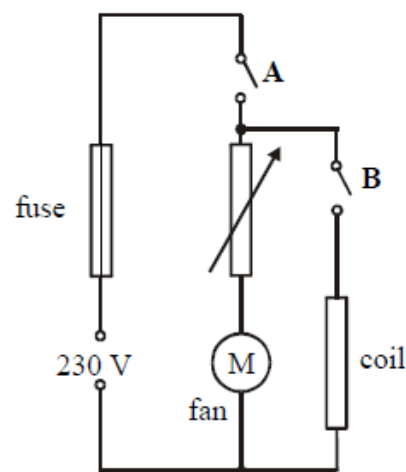

2017 Question 8 {first 8 parts} [Higher Level]

- (i) Distinguish between resistance and resistivity.
- (ii) What is the effect on the resistance of a length of wire if the diameter of the wire is increased by a factor of three?

In the circuit diagram shown, the a.c. supply has an rms voltage of 12 V.
The variable resistor is set at 500 Ω .

- (iii) What is meant by rms?
- (iv) What is meant by a.c.?
- (v) Calculate the effective resistance of the circuit
- (vi) Calculate the current flowing in the 200 Ω resistor.
- (vii) The variable resistor is then removed.
What effect will this have on the current flowing in the 50 Ω resistor?
- (viii) Explain your answer.

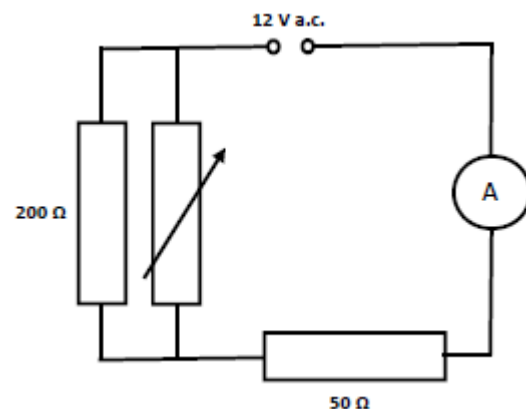

Wheatstone bridge and metre bridge

2012 Question 9 [Higher Level]

- Define resistance.
- Two resistors of resistance R_1 and R_2 are connected in series.
Derive an expression for the effective resistance of the two resistors in terms of R_1 and R_2 .
- Two $4\ \Omega$ resistors are connected in parallel.
Draw a circuit diagram to show how another $4\ \Omega$ resistor could be arranged with these two resistors to give an effective resistance of $6\ \Omega$.
- A fuse is a resistor used as a safety device in a circuit. How does a fuse operate?

A Wheatstone bridge circuit is used to measure the resistance of an unknown resistor R . The bridge ABCD is balanced when $X = 2.2\ \text{k}\Omega$, $Y = 1.0\ \text{k}\Omega$ and $Z = 440\ \Omega$.

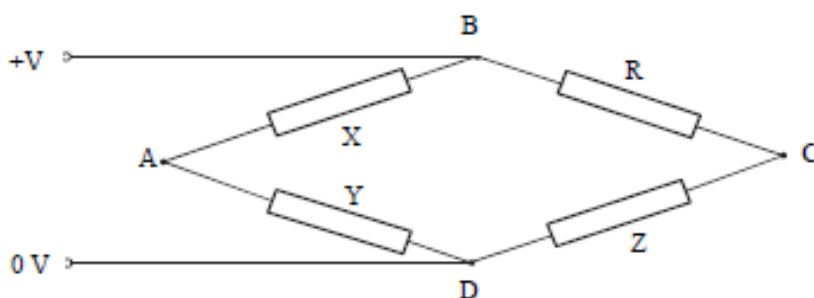

- What test would you use to determine that the bridge is balanced?
- What is the resistance of the unknown resistor R ?
- When the unknown resistor R is covered by a piece of black paper, the bridge goes out of balance. What type of resistor is it? Give a use for this type of resistor.

2014 Question 10 {second half}

- The resistance of the conductor in a strain gauge increases when a force is applied to it. Strain gauges can act as the resistors in a Wheatstone bridge, and any change in their resistance can then be detected.
How would an observer know that a Wheatstone bridge is balanced?

The Wheatstone bridge in the diagram is balanced.

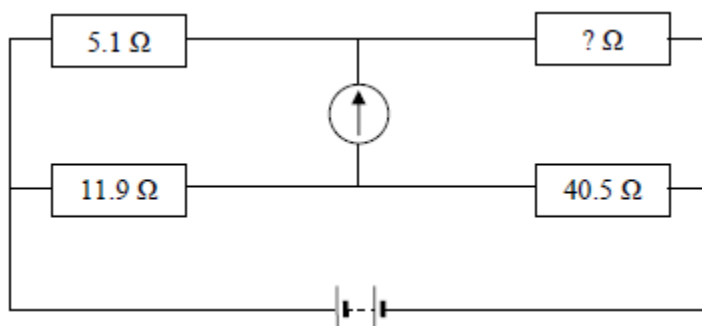

- What is the resistance of the unknown resistor?
- Write an expression for the resistance of a wire in terms of its resistivity, length and diameter.
- The radius of a wire is doubled. What is the effect of this on the resistance of the wire?

2007 Question 9 [Higher Level]

- (i) Define resistance.
- (ii) Define resistivity.

A metre bridge was used to measure the resistance of a sample of nichrome wire.

The diagram indicates the readings taken when the metre bridge was balanced.

The nichrome wire has a length of 220 mm and a radius of 0.11 mm.

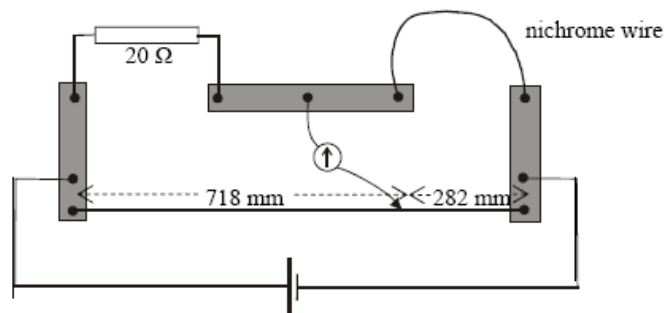

- (i) Calculate the resistance of the nichrome wire
- (iii) Calculate the resistivity of nichrome.
- (iv) Sketch a graph to show the relationship between the temperature and the resistance of the nichrome wire as its temperature is increased.
- (v) What happens to the resistance of the wire as its temperature falls below 0°C ?
- (vi) What happens to the resistance of the wire as its length is increased?
- (vii) What happens to the resistance of the wire if its diameter is increased?
- (viii) Name another device, apart from a metre bridge, that can be used to measure resistance.
- (ix) Give one advantage and one disadvantage of using this device instead of a metre bridge.

Solutions to ordinary Level *maths* questions

2013 Question 9 (b) [Ordinary Level]

(i) **State Ohm's law.**

The current through a conductor is directly proportional to the voltage

(ii) **Calculate the total resistance of the circuit.**

$$6 + 12 = 18 \Omega$$

(iii) **Calculate the current in the circuit.**

$$I = \frac{V}{R} = \frac{3}{18} = 0.166 \text{ A}$$

(iv) **Calculate the potential difference across the 6 Ω resistor.**

$$V = IR = (0.166)(6) = 1 \text{ V}$$

(v) **Name an instrument used to measure potential difference.**

voltmeter

2013 Question 12 (d) [Ordinary Level]

(i) **State Ohm's law.**

Ohm's Law states that the current flowing through a conductor is directly proportional to the potential difference across it, assuming constant temperature.

(ii) **What is the total resistance of the circuit?**

$$500 \text{ } (\Omega)$$

(iii) **What is the current in the circuit?**

$$I = V/R = 6/500 = 1.2 \times 10^{-3} \text{ A}$$

(iv) **What is the potential difference across the 50 Ω resistor?**

$$V = IR = (1.2 \times 10^{-3})(50) = 0.6 \text{ V}$$

(v) **What would happen to the resistance of the circuit if the temperature were increased?**

It would decrease

2010 Question 9 (b) [Ordinary Level]

(i) **State Ohm's law**

Ohm's Law states that the current flowing through a conductor is directly proportional to the potential difference across it, assuming constant temperature.

(ii) **Calculate the combined resistance of the 15 Ω and 30 Ω resistors in parallel.**

$$\frac{1}{R_{15,30}} = \frac{1}{15} + \frac{1}{30}$$

$$\frac{1}{R_{15,30}} = \frac{1}{10}$$

$$R_{15,30} = 10 \Omega$$

(iii) **Calculate the total resistance of the circuit:** Total resistance of the circuit = $10 + 10 + 4 = 24 \Omega$.

(iv) **Calculate the current flowing in the circuit**

$$R = \frac{V}{I}$$

$$I_{total} = \frac{V_{total}}{R_{total}}$$

$$I_{total} = \frac{12}{24}$$

$$I_{total} = 0.5 \text{ A}$$

2008 Question 9 [Ordinary Level]

(i) **What is an electric current?**

An electric current is a flow of charge.

(ii) **Give two effects of an electric current.**

Heating, magnetic, chemical.

(iii) **Name a source of potential difference.**

Battery, generator, thermocouple.

(iv) **Describe an experiment to investigate if a substance is a conductor or an insulator.**

Apparatus: circuit to show power source, ammeter/ bulb, leads,

Procedure: connect the circuit and place item between contacts

Observation: If the bulb lights then the item is a conductor; if the bulb does not light then the item is an insulator.

(v) **The two headlights of a truck are connected in parallel to a 24 V supply.**

Draw a circuit diagram to show how the headlights are connected to the supply.

Circuit diagram showing battery and two bulbs connected in parallel.

(vi) **What is the advantage of connecting them in parallel?**

If one goes the other still works, they are brighter.

(vii) **Why should a fuse be included in such a circuit?**

To prevent too high a current flowing.

(viii) **The resistance of each headlight is 20 Ω . Calculate the total resistance in the circuit.**

For resistors in parallel we use the formula

$R = 10 \Omega$

$$\frac{1}{R} = \frac{1}{R_1} + \frac{1}{R_2} = \frac{1}{20} + \frac{1}{20} = \frac{1}{10}$$

(ix) **Calculate the current flowing in the circuit.**

$V = IR$ $I = V/R$ $I = 24/10 = 2.4 \text{ A}$.

2007 Question 12 (c) [Ordinary Level]

(i) **State Ohm's law.**

Ohm's Law states that the current flowing through a conductor is directly proportional to the potential difference across it, assuming constant temperature.

(ii) **Calculate the total resistance of the circuit.**

$R = 3 + 9 = 12 \Omega$

(iii) **Calculate the current in the circuit.**

$V=IR \Rightarrow I = V/R = 6/12 = 0.5 \text{ A}$

(iv) **Calculate the potential difference across the 9 Ω resistor.**

$V = IR = 0.5 \times 9 = 4.5 \text{ V}$

(v) **Name an instrument used to measure potential difference.**

A voltmeter

2005 Question 8 [Ordinary Level]

(i) **State Ohm's Law.**

Ohm's Law states that the current flowing through a conductor is directly proportional to the potential difference across it, assuming constant temperature.

(ii) **Which conductor obeys Ohm's law?**

The metal.

(iii) **Explain your answer.**

Graph (a) results in a straight line through the origin, therefore I is proportional to V

(iv) **Calculate the total resistance of the circuit.**

$$R_{\text{Total}} = R_1 + R_2 \quad \Rightarrow \quad R_{\text{Total}} = 100 + 500 = 600 \, \Omega.$$

(v) **Calculate the current flowing in the circuit.**

$$V = I R \quad \Rightarrow \quad I = V/R \quad \Rightarrow \quad I = 6/600 = 0.01 \text{ A}$$

(vi) **Calculate the potential difference across the 100 Ω resistor.**

$$V = I R \quad \square \quad V = (0.01) \times (100) \quad \square \quad V = 1 \text{ V.}$$

(vii) **As the thermistor is heated, what happens to the resistance of the circuit?**

It decreases.

(viii) **As the thermistor is heated, what happens to the potential difference across the 100 Ω resistor?**

It increases, because the total voltage is still 6 V is still the potential difference across both resistors, so if the potential difference decreases across the thermistor, it must increase across the 100 Ω resistor.

(ix) **Give a use for a thermistor.**

Thermometer, heat sensor, temperature control.

2002 Question 8 [Ordinary Level]

(i) **Explain potential difference.**

The Potential difference between two points is the work done in bringing a charge of 1 Coulomb from one point to the other.

(ii) **Explain electric current.**

An electric current is a flow of charge.

(iii) **Give one difference between conduction in metals and conduction in semiconductors.**

There are two types of charge carriers (holes and electrons) in semiconductors, whereas with metals electrons are the only charge carriers.

Conduction increases with temperature for semiconductors whereas conduction decreases with temperature for metals.

(iv) **A circuit consists of a 3 Ω resistor and a 6 Ω resistor connected in parallel to a 1.5 V d.c. supply as shown. Calculate the total resistance of the two resistors.**

$$1/R = 1/3 + 1/6 \quad \square \quad 1/R = 1/2 \quad \square \quad R = 2 \Omega.$$

(v) **Calculate the current flowing in the circuit.**

$$V = IR \quad \square \quad I = V/R \quad \square \quad I = 1.5/2 = 0.75 \text{ A}$$

(vi) **What is the current in the 3 Ω resistor?**

Voltages in parallel are the same and the supply voltage is in parallel with the 3 Ω resistor, so the voltage across the 3 Ω resistor is also 1.5 Volts $\square \quad I = 1.5/3 = 0.5 \text{ A}$

(vii) **Semiconductors can be made p-type or n-type. How is a semiconductor made p-type?**

By doping it with Boron.

(viii) **Draw a diagram showing a p-n junction connected in forward bias to a d.c. supply.**

(ix) **Give two uses of semiconductors.**

Rectifiers, transistors, diodes, thermistors, thermometers, radios/TV, etc.

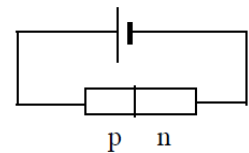

Solutions to *all higher level questions*

2017 Question 8 {solution to 1st 8 parts}

(i) **Distinguish between resistance and resistivity.**

The resistance of a conductor is the ratio of the potential difference across it to the current flowing through it.

Resistivity is defined as the resistance of a cube of material of side one metre.

(ii) **What is the effect on the resistance of a length of wire if the diameter of the wire is increased by a factor of three?**

The cross-sectional area A of a wire $= \pi r^2 = \pi \left(\frac{d}{2}\right)^2$

So area is proportional to the square of the diameter.

So if the diameter goes up by a factor of 3, the area will go up by a factor of 9.

Now what's the relationship between resistance and area?

$$\rho = \frac{RA}{l} \quad R = \frac{\rho l}{A}$$

So R is inversely proportional to A .

So if the area goes up by a factor of the 9 the resistance will go down by a factor of 9 (get 9 times smaller)

Answer: The resistance decreases by a factor of 9

(iii) **What is meant by rms?**

Average (or 'root mean square') voltage

(iv) **What is meant by a.c.?**

The current changes direction (alternating current).

(v) **Calculate the effective resistance of the circuit**

$$\frac{1}{R_{\text{Total}}} = \frac{1}{R_1} + \frac{1}{R_2} \quad \frac{1}{R_{\text{Total}}} = \frac{1}{200} + \frac{1}{500} \quad R_P = 143 \Omega \quad R_{\text{Total}} = 143 + 50 = 193 \Omega$$

(vi) **Calculate the current flowing in the 200 Ω resistor.**

$$I_T = \frac{V}{R} = I_T = \frac{12}{193} = 0.062 \text{ A}$$

Look for the isolated resistor

50 Ω resistor:

$$I = 0.062 \text{ A}, R = 50 \Omega. \quad V = IR = (0.062)(50) = 3.1 \text{ Volts}$$

Look at remaining resistors

The voltage across the two resistors in parallel $= 12 - 3.1 = 8.9 \text{ V}$, so the potential difference across both the 15 Ω and the 30 Ω resistors is 8.9 Volts.

To find I use $I = V/R$

Current through 200 Ω resistor $= 8.9/200 = 0.045 \text{ Amps}$

(vii) **What effect will this have on the current flowing in the 50 Ω resistor?**

The overall current will reduce

(viii) **Explain your answer.**

Resistance of circuit is now greater

You could work this out mathematically if you were so inclined. Alternatively you could look at it from the perspective that there is one less path for the current to flow through.

2014 Question 10 {second half} [Higher Level]

(i) How would an observer know that a Wheatstone bridge is balanced?
 zero reading on / no deflection of / no current flowing through galvanometer

(ii) What is the resistance of the unknown resistor?
 The formula for a balanced Wheatstone bridge is as follows:

$$\frac{R_1}{R_2} = \frac{R_3}{R_4} \quad \frac{5.1}{R_2} = \frac{11.9}{40.5} \quad R_2 = \frac{(5.1)(40.5)}{11.9} \quad R_2 = 17.36 \Omega$$

(iii) Write an expression for the resistance of a wire in terms of its resistivity, length and diameter.

$$R = \frac{\rho l}{A} \quad A = \pi r^2 \text{ or in terms of diameter } A = \pi \frac{d^2}{4} \quad \Rightarrow R = \frac{4\rho l}{\pi d^2}$$

(iv) The radius of a wire is doubled. What is the effect of this on the resistance of the wire?

$$R \propto \frac{1}{d^2}$$

\Rightarrow if the radius (or the diameter) goes up by a factor of 2, then the resistance goes *down* by a factor of 4.

2013 Question 8 (b) [Higher Level]

(i) Explain why high voltage is used.
 High voltage uses low current minimising heat loss

(ii) Calculate the resistance of the aluminium wire.

$$\rho = \frac{RA}{l} \quad R = \frac{\rho l}{A}$$

Diameter = 18 mm $r = 9 \times 10^{-3}$ m

$$A = \pi r^2 = \pi(9 \times 10^{-3})^2$$

ρ = resistivity of aluminium = $2.8 \times 10^{-8} \Omega \text{ m}$

$l = 3000$ m

$$R = \frac{(2.8 \times 10^{-8})(3000)}{\pi(9 \times 10^{-3})^2}$$

$R = 0.33 \Omega$

(iii) Calculate how much electrical energy is converted to heat energy in the wire in ten minutes.

$$W = I^2 R t$$

$$W = (250)^2(0.33)(600) = 1.238 \times 10^7 \text{ J}$$

2011 Question 12 (c) [Higher Level]

- (i) **List the factors that affect the heat produced in a current-carrying conductor.**

Resistance, current (squared), time

- (ii) **Calculate the maximum resistance per metre of the wire**

$$P = RI^2$$

$$2.7 = R(20)^2$$

$$R = \frac{2.7}{400} = 6.75 \times 10^{-3} \Omega$$

- (iii) **Calculate the minimum diameter of the wire (resistivity of copper = $1.7 \times 10^{-8} \Omega \text{ m}$).**

$$\rho = \frac{RA}{l}$$

$$A = \frac{\rho l}{R}$$

$$\pi r^2 = \frac{\rho l}{R}$$

$$r^2 = \frac{\rho l}{\pi R}$$

$$r^2 = \frac{(1.7 \times 10^{-8})(1)}{\pi(6.75 \times 10^{-3})} = 8.017 \times 10^{-7} \quad r = 9.0 \times 10^{-4} \text{ m} \quad \text{diameter} = 1.8 \times 10^{-3} \text{ m}$$

2010 Question 8 [Higher Level]

- (i) **What is an electric current?**

An electric current is a flow of charge

- (ii) **Heating is one effect of an electric current. Give two other effects of an electric current.**

Magnetic and chemical

- (iii) **Describe what happens when switch A is closed and the rheostat is adjusted**

The fan operates and its speed of rotation changes.

- (iv) **Describe what happens when switch A and switch B are closed.**

Current flows through coil and the coil gets hot.

The fan blows hot air

- (ix) **Calculate the current that flows through the coil when the dryer is turned on.**

$$P = VI \quad I = \frac{P}{V} = \frac{2000}{230} \quad I = 8.7 \text{ A}$$

- (v) **What is the initial resistance of the coil?**

$$V = RI \quad R = \frac{V}{I} = \frac{230}{8.7} = 26.4 \Omega$$

- (x) **Calculate the length of the coil of wire.**

$$A = \pi r^2$$

$$A = (3.14)(0.085 \times 10^{-3})^2$$

$$A = 2.27 \times 10^{-8} \text{ m}^2$$

$$\rho = \frac{RA}{l}$$

$$l = \frac{RA}{\rho}$$

$$l = \frac{(26.4)(2.27 \times 10^{-8})}{1.1 \times 10^{-6}}$$

$$l = 0.545 \text{ m}$$

- (xi) **Explain why the current through the coil would decrease if the fan developed a fault and stopped working.**

The coil gets hot therefore its resistance increases

2008 Question 7

- (i) **Define resistivity and give its unit of measurement.**

Resistivity is defined as the resistance of a cube of material of side 1 m.

- (ii) **What is the difference between convection and radiation as a means of heat transfer?**

Convection requires a medium, radiation does not.

- (iii) **Calculate the resistivity of nichrome.**

$$A = \pi r^2 = \pi (1.1 \times 10^{-3})^2 = 3.80 \times 10^{-6} \text{ m}^2$$

$$\rho = \frac{RA}{l} \quad \rho = \frac{(12)(3.80 \times 10^{-6})}{40} \quad \rho = 1.14 \times 10^{-6} \Omega \text{ m.}$$

- (iv) **Calculate the heat generated by the toaster in 2 minutes if it has an efficiency of 96%.**

$$\text{Heat generated} = \text{power} \times \text{time} = (1050)(120) = 1.26 \times 10^5 \text{ J}$$

$$96\% \text{ of } 1.26 \times 10^5 = 1.21 \times 10^5 \text{ J}$$

- (v) **The toaster has exposed metal parts. How is the risk of electrocution minimised?**

The metal parts are earthed.

- (vi) **Explain, in terms of movement of electrons, why light is emitted when a metal is heated.**

Electrons gain energy and jump to higher energy state. Then when they fall back down they emit electromagnetic radiation in the form of light.

2007 Question 9

(i) Define resistance.

The resistance of a conductor is the ratio of the potential difference across it to the current flowing through it.

(ii) Define resistivity.

The resistivity of a material is defined as the resistance of a cube of material of side 1 m.

(iii) Calculate the resistance of the nichrome wire

$$\frac{R_1}{R_2} = \frac{l_1}{l_2} \quad \frac{R}{20} = \frac{282}{718} \quad R = 7.86 \, \Omega$$

(iv) Calculate the resistivity of nichrome

$$A = \pi r^2 = (\pi)(.11 \times 10^{-3})^2 = 3.801 \times 10^{-8} \, \text{m}^2$$

$$\rho = \frac{RA}{l} \quad \rho = \frac{(7.855)(3.801 \times 10^{-8})}{0.220} \quad \rho = 1.36 \times 10^{-6} \, \Omega \, \text{m}$$

(v) Sketch a graph to show the relationship between the temperature and the resistance of the nichrome wire as its temperature is increased.

Axes labelled R and T (or θ)

Correct linear graph with intercept showing R greater than zero.

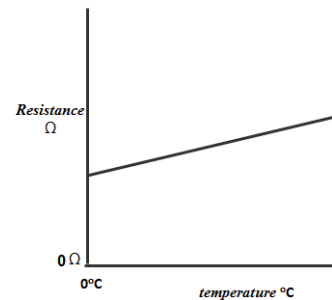

(vi) What happens to the resistance of the wire as its temperature falls below 0°C?

R decreases

(vii) What happens to the resistance of the wire as its length is increased?

R increases

(viii) What happens to the resistance of the wire if its diameter is increased?

R decreases

(ix) Name another device, apart from a metre bridge, that can be used to measure resistance.

Ohmmeter / wheatstone bridge / multimeter.

(x) Give one advantage and one disadvantage of using this device instead of a metre bridge.

Ohmmeter: Advantage: compact, portable, faster method

Disadvantage: less accurate

2005 Question 9

(i) **Define potential difference.**

Potential difference is the work done in bringing unit charge from one point to another.

(ii) **Define resistance.**

Resistance of a conductor is the ratio of the potential difference across it to the current passing through it.

(iii) **Derive an expression for the effective resistance of the two resistors in terms of R_1 and R_2 .**

For currents in parallel: $I_{\text{Total}} = I_1 + I_2$

But $I = \frac{V}{R}$ (Ohm's Law)

$$\Rightarrow \frac{V}{R_T} = \frac{V}{R_1} + \frac{V}{R_2}$$

We can now cancel the V 's because the voltage is the same for resistors in parallel

$$\Rightarrow \frac{1}{R_T} = \frac{1}{R_1} + \frac{1}{R_2}$$

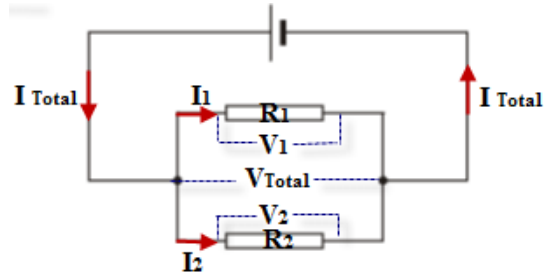

(iv) **At room temperature calculate the total resistance of the circuit.**

For the two resistors in parallel $\frac{1}{R_{\text{parallel}}} = \frac{1}{R_1} + \frac{1}{R_2}$ $\frac{1}{R_p} = \frac{1}{500} + \frac{1}{750}$ $R_p = 300 \Omega$

$$R_{\text{Total}} = 300 + 300 = 600 \Omega$$

(v) **At room temperature calculate the current flowing through the 750 Ω resistor.**

$$I_{\text{Total}} = \frac{V_{\text{Total}}}{R_{\text{Total}}} = \frac{6}{600} = 0.01 \text{ A}$$

$$V_{300} = I_{300}R_{300} = (0.01)(300) = 3 \text{ V}$$

The voltage across the resistors in parallel corresponds to the total voltage minus the voltage across the 300 Ω resistor.

$$\Rightarrow V_p = 6 - 3 = 3 \text{ V.}$$

Now for the 750 Ω resistor we know both the voltage and the resistance: $I_{750} = \frac{3}{750} = .004 \text{ A} = 4 \text{ mA}$

(vi) **As the temperature of the room increases, explain why the resistance of the thermistor decreases.**

The thermal energy absorbed by the thermistor releases lots of electrons from the individual atoms which now become available for conduction.

{This effect is much greater than the increased resistance due to the greater thermal agitation of the atoms.}

(vii) **As the temperature of the room increases, explain why the potential at A increases.**

{In this context the phrase 'potential at a point' means the potential between that the point and the negative end of the battery. There was no way for you to know this- it certainly wasn't on the syllabus 😊}

The resistance of thermistor (and 750 Ω combination) decreases.

Therefore the potential difference across thermistor and 750 Ω combination decreases.

The voltage across the resistors in parallel corresponds to the total voltage minus the voltage across the 300 Ω resistor.

Therefore the voltage across the 300 Ω resistor increases.

Therefore the potential at A increases.

2002 Question 8

(i) Define power.

Power is the rate at which work is done. $Power = \frac{work}{time}$

(ii) Define resistivity.

Resistivity is the resistance of a cube of material of side one metre.

(iii) Describe an experiment that demonstrates the heating effect of an electric current.

Connect an electrical calorimeter containing water to a power supply and notice the increase in temperature using a thermometer.

(iv) Calculate the total resistance of the cables.

$$\rho = \frac{RA}{l} \quad A = \pi r^2 = \pi(0.005)^2 = 7.85 \times 10^{-5} \text{ m}^2$$

$$R = \frac{\rho l}{A} \quad R = \frac{(5.0 \times 10^{-8})(15000)}{7.85 \times 10^{-5}} \quad \Rightarrow R = 9.6 \Omega$$

(v) Calculate the current flowing in the cables.

$$P = VI \quad \Rightarrow \quad I = \frac{P}{V} \quad I = \frac{2 \times 10^6}{10000} = 200 \text{ A}$$

(vi) Calculate the rate at which energy is “lost” in the cables.

Note that in this context P corresponds to the power losses due to the heating effect (and not the power rating of the generating station).

Similarly the potential difference in this context corresponds to the potential drop across the cable and not the supply voltage.

$$P = I^2 R = (200)^2(9.6) = 3.8 \times 10^5 \text{ W}$$

(vii) Suggest a method of reducing the energy “lost” in the cables.

Higher voltage which would mean lower current / thicker cable for lower resistance